

3mm Blue Plastic Silicon PIN photodiode

Model: LSSPD-PB3

This high speed and high sensitive PIN photodiode in a standard 5 plastic package. The device is spectrally matched to infrared emitting diode.

Features:

- High responseivity
- Low dark current
- High speed
- Small size
- Low cost

Applications:

- Industrial automatic control
- Optical measurement equipment
- audio equipment, air conditioner, etc.

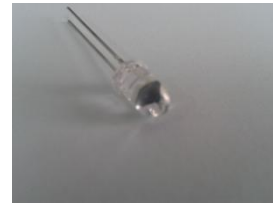

Absolute maximum ratings:

parameter	symbol	value	unit
Operating temperature	Top	-25~+85	°C
Storage temperature	Tstg	-40~+85	°C
Forward current	I _f	10	mA
Reverse current	I _r	1000	uA
Soldering temperature(time)	T _s (10s)	260	°C

Electrical and optical characteristics:(T=25°C)

parameter	symbol	unit	Value (typ.)
Active area	Φ	mm	3×3
Spectral range	λ	nm	300-1200
Responsivity	Re (λ=1200nm)	mA/mW	0.1
	Re (λ=940nm)	mA/mW	0.5
	Re(λ=650nm)	mA/mW	0.35
	Re(λ=300nm)	mA/mW	0.1
Open-Circuit Voltage	VOC(Ee=1mW/cm ² ,p=940nm)	V	0.4
Short-Circuit Current	ISC(Ee=1mW/ cm ² ,p=940nm)	uA	40
Reverse Light Current	IL(Ee=1mW/cm ² ,p=940nm VR=5V	uA	40
Dark current	I _D (VR=10V)	nA	10
Rise time	T _r (VR=10V, RL=1000)	ns	40
Reverse Breakdown voltage	V _{BR} (I _R =100uA)	V	170
Junction capacitance	C _j (f=1MHz, VR=5V)	pF	18
Operating voltage	V _R	v	0-10
package	Plastic package 5		

The typical characteristic curve

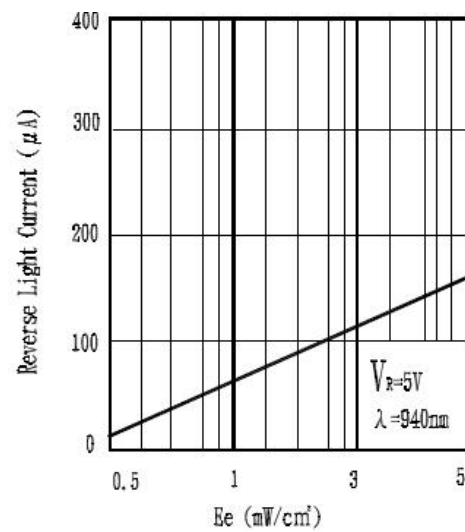
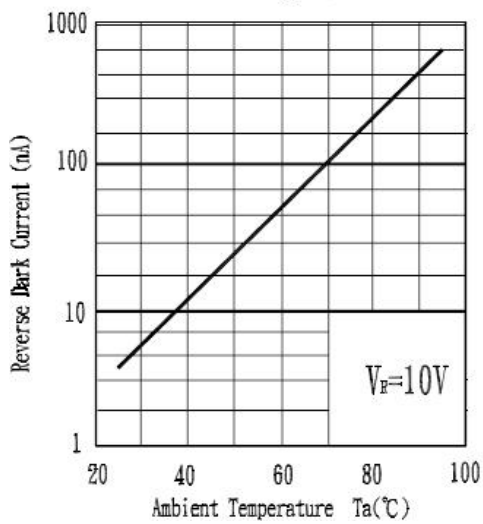
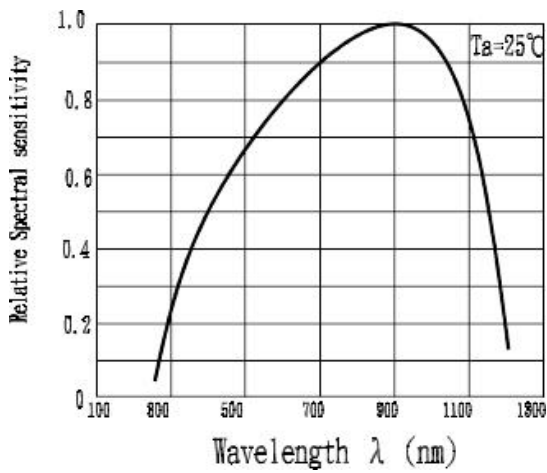

The package Dimensions

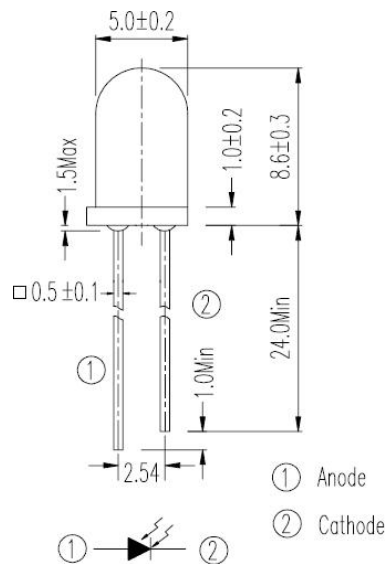
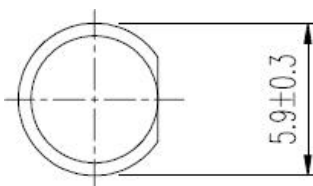

The cautions: The suitable ESD protection is required in storage, transportation and using.